

# MCNARY SPILLWAY STATUS

FPOM  
26 September 2024



U.S. ARMY  
US Army Corps  
of Engineers®



# MCNARY SPILLWAY

- Operational in 1954
- 22 Spillbays with double leaf vertical lift gates
- 2 Cranes (#6, #7) only initially,  
200 ton (400,000 lbs) capacity.  
Routinely operated gates in split leaf





# MCNARY CRANES 6 & 7

- Overloaded by estimated 20% according to BDI tests in 2003/05- not counting for lifting beam or frictional losses. – Violation of American Society of Mechanical Engineers (ASME) and Engineer Manual (EM) 385.
- Gantry crane frames do not comply with current American Institute of Steel Construction (AISC) codes - Under breakdown torque simulations, the downstream legs fail.
- The electrical system is outdated. Asbestos. DC hoist controls at risk of failure. Obsolete component replacement is becoming more challenging.
- Frequently down for weeks or months at a time – most recently a gantry drive gearbox failure required bearings that are no longer readily available.
- Recently had a main hoist gearbox replacement to address severe vibration issues, with mixed results.
- January 2023, Cranes 6 & 7 were limited to two engineered lifts (250 tons) per year.
  - Lifts that do not overload crane capacity are not limited

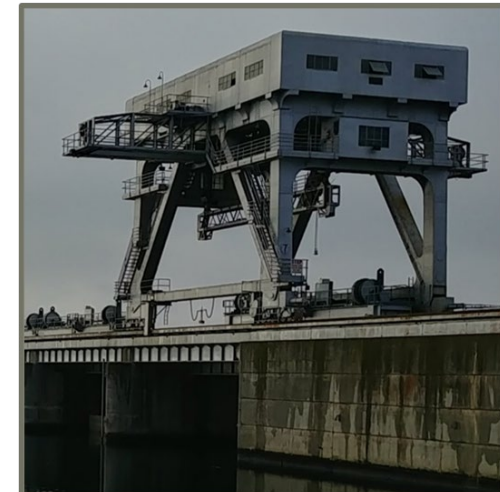



# MCNARY HOISTS

- 1976, 16 Ederer hoists added, 175 tons (350,000 lbs) capacity  
Flow deflectors added  
Spillway predominately operated as full gates
- 2002/2003, Four Transco hoists added.  
350,000 lbs capacity
- 2002, Failure of hoist gearbox coupler
- 2003-2005, Testing indicated all hoists were overloaded, 13 were > 125% overloaded  
Up to 480,000 lbs of load. Did not include sheave friction.
- 2004-2009, Rehab of some gates wheel bearings, guide slots, guide shoes, replaced seals  
Minor improvement only
- 2007, Hoist replacement project initiated
- 2020, Work restriction while hoists were under load implemented to reduce risk to health and human safety
- 2021, Load cell data collected on four hoists for prototype hoist project showed overload condition
- 2022, Hoist #6 failed, gears showed severe pitting due to material fatigue from high contact stresses, replaced with hoist from bay #16. Bay #16 RTS after about three month outage.  
Hoist #15 OOS for one week for repairs  
Hoist #20 taken OOS for repairs  
Hoist #21 gearbox coupler failed and brakes failed during closure causing gate to fall on sill
- October 2023, Hoist operations were limited to either no (13) or two (7) overload lifts per year





Pitted north drum gear



Unworn gear



# MCNARY HOISTS



Pitting on south pinion gear

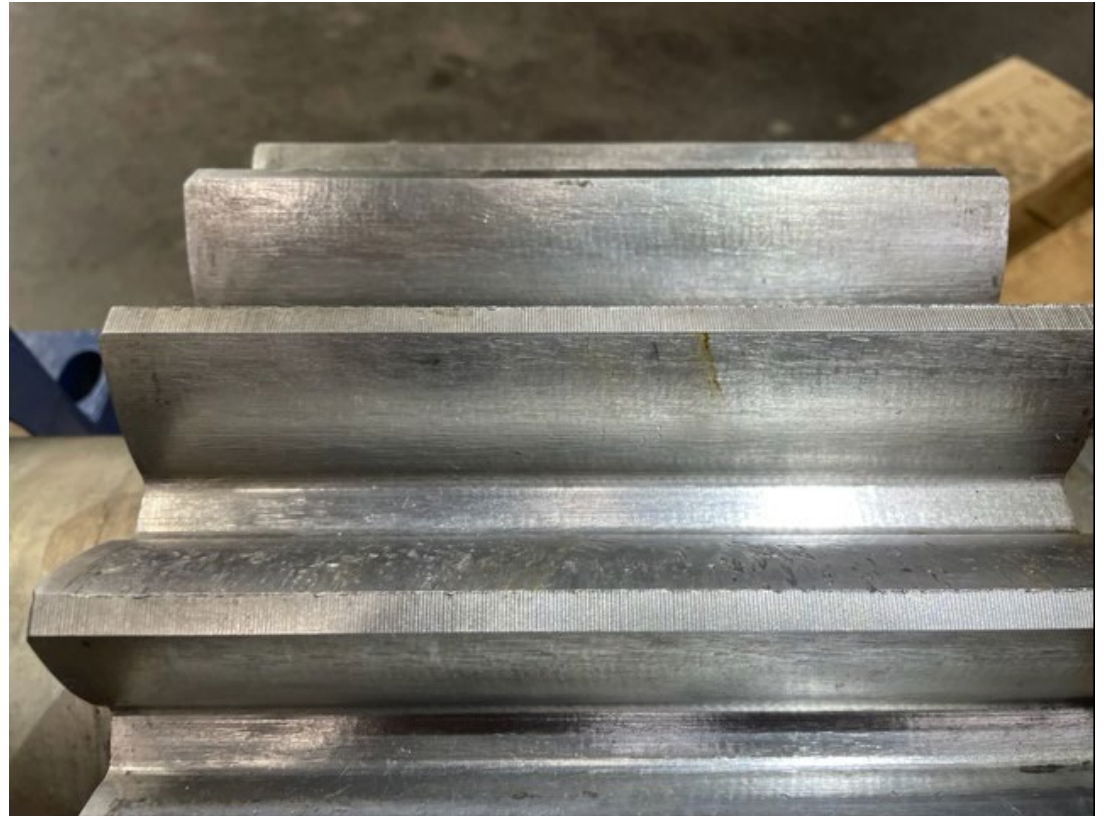

Unworn pinion gear



# MCNARY SPILL GATES

- 2022, Testing of lifting eyes showed deterioration and overload of design capacity  
Gate girders; several were close to failure for normal operations, and many did not meet criteria for emergency operation
- 2023, Spillbay #16 closed to repair cracks in dogs and dog mounting points  
Bays #1, #3, #21 taken OOS to repairs dogs. Other bays to follow over the next year
- Result of structural analysis is that all 22 (+2 spares) spill gates should be replaced



# MCNARY SPILLWAY UPGRADE STATUS

## SCOPE OF SPILLWAY UPGRADES

### Spillway Gate Dogging Mechanism Repairs (NREX):

- Repair and restore dogging mechanisms to allow safe dogging of gates.

### Replace Spillway Cranes 6 & 7 (BPA Joint Capital):

- Replace spillway gantry cranes with uprated (350 ton) cranes (**PRIORITY**)
- Replace spillway gate lifting beams with uprated lifting beams

### Gate Hoist Replacements (BPA Joint Capital):

- Replace all 20 gate hoists (**PRIORITY**). **Add 2 new gate hoists** so each spill bay has a hoist. 350 ton capacity

### Spillway Gate Replacement (BPA Joint Capital):

- Based on 2023 structural analysis, we must replace all spillway gates with uprated capacity for sheave friction and hydraulic down-pull forces.

### Spillway Gate Repair Pit Upgrade (BPA Joint Capital):

- Remove lead and asbestos.
- Add explosion-proof lighting, ventilation, doorways, electrical, pedestal upgrades, deck slab repairs and handrail upgrades, and fire protection.

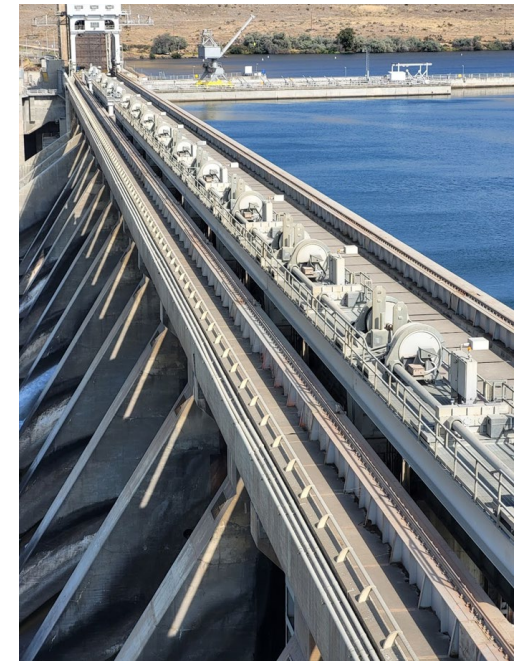
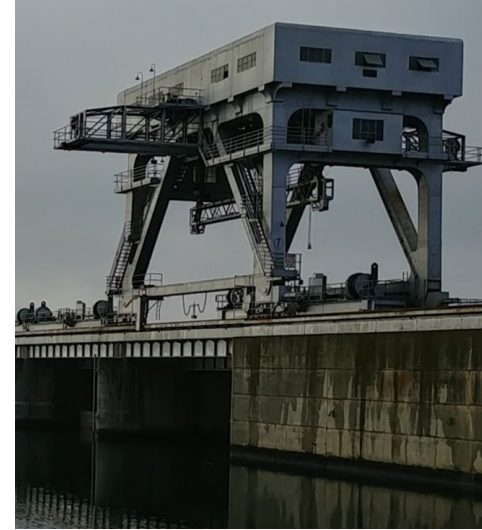



# MCNARY SPILLWAY UPGRADE STATUS

## SCOPE OF SPILLWAY UPGRADES

### Spillway Deck Safety Handrail (NREX):

- Procure 22 new sets of handrail for the upstream spillway gate slots
- Move 13 spillway gates and spillway gate hoists to upstream slots
- Operate spillway in upstream, split-leaf configuration for spill and fish passage requirements (**PRIORITY**)

### Spillway Lifting Auxiliary Beams (SLABs) (BPA Joint Capital):

- Purchase new SLABs to allow use of spillway cranes without overloading (**PRIORITY**)
- Reduces spillway gate load from the spillway cranes and allows spillway crane operation within acceptable load limits

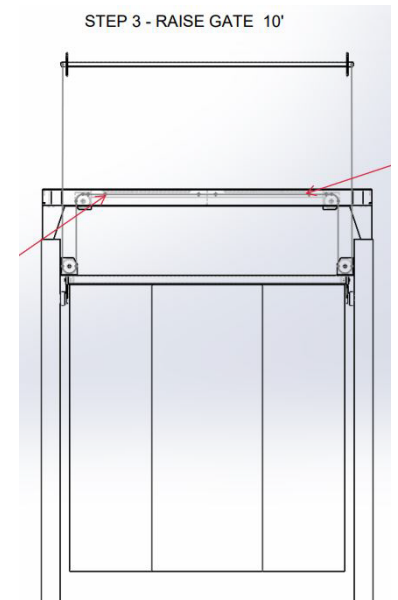
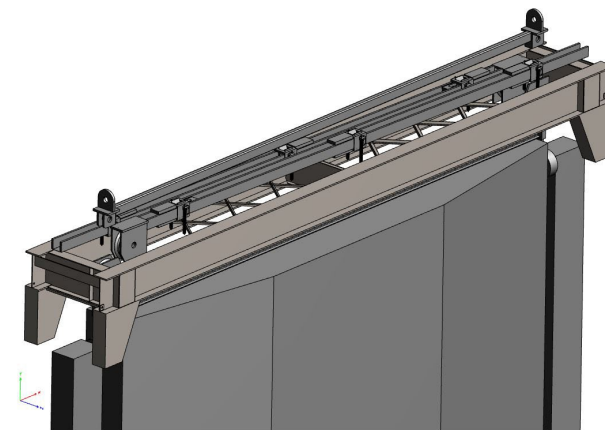



# MCNARY SPILLWAY CRANE MILESTONES

Kick off	August 2023
<b><i>Phase 1 Approval</i></b>	April 2024
Ready to Advertise	September 2024
Award	March 2025
Onsite Construction	Summer 2027





# SPILLWAY GATE HOIST REPLACEMENTS

## MILESTONES

Kick off	Dec 2014
Phase 1 Approval	Nov 2019
Phase 2a Approval	Jul 2022
<b><i>Contract Award</i></b>	Apr 2024
Onsite Construction	Apr 2025
Phase 2b Approval	Jun 2024
Contract Award	Nov 2024
Onsite Construction	Sep 2025 – 2032 (~Three per year)

Phase 2a = Prototype Spillway Gate Hoist (1 hoist)

Phase 2b = Remaining Spillway Gate Hoists (21 hoists)



# SPILLWAY GATE HOIST REPLACEMENTS

## McNary Spillway Hoist Phase 1:

- prepare plans and specifications based on recommended alternatives, including a “prototype” rehabilitation of one gate and uprate of one hoist
- prepare contract documents to BCOES level
- prepare total project cost estimate
- advertise contract and pre-award acquisition actions

Operational requirements for the new spillway gate hoist:

Hoist Designation	Gate hoist
Rated Capacity	400 tons (800,000 lbs)
Lift Speed	1 ft/min
Motor Power	40 HP max
Picking Distance	20 ft(Gate Opening)
Over Travel	1 ft
Rated Voltage	480 V

New hoist motor capable of 200 percent overload torque for one minute from zero speed to base speed.

Include a new gate lifting beam rated to match 400 ton capacity.

Use commercially available off-the-shelf components as much as is feasible



# SPILLWAY GATE HOIST REPLACEMENTS

## **McNary Spillway Hoist Phase 1 (continued):**

Equipment such as motors, reducers, gearboxes, etc. shall allow for easy extraction and installation.

Use Environmentally Acceptable Lubricant (EAL) for components not permanently sealed.

Include a load-limit visual/audible system for when the load-limit has been exceeded. The load-limit system shall include load-sensing electronics and an alarm light. The alarm setpoint shall be adjustable.

Include load cells to provide continual load measurement signals with an emergency stop pushbutton.

One of each item, rating and type of equipment furnished as selected by the Contracting Officer, shall be given a complete test witnessed by the Contracting Officer. No equipment shall be shipped until it has been approved for shipment by the Contracting Officer.

Each hoist shall be given a complete functional test after installation with the gate attached.



- **McNary Spillway Working Schedule**

- MCN Replace Spillway Cranes 6 & 7
  - Phase 1a under way. Presented to CWG, *Working to finalize funding agreements so can start Phase 1 Design.*
  - Phase 1 Design FY24-25? (pending appropriated \$\$s) – *Phase 1 scheduled for FY25-26. Appropriated match available.*
  - Award 1 crane (pending appropriated \$\$s): - *scheduled for FY26 (pending appropriated \$\$)*
  - Start fabrication crane 1 in FY26
  - Award 2<sup>nd</sup> crane (pending appropriated \$\$s): *possibly FY26, depending on appropriated \$\$.*
- MCN Spillway Major Rehab Evaluation Report (MRER)
  - Creating new project for FY24-25 budget request – *no project needed, MRER waiver signed by Commander and routed to HQ.*
- MCN Spillway Hoist Replacements
  - First hoist in final design
  - Prototype contract awarded. Install FY26-Early FY27
  - Award follow-on contract for remaining hoists FY26: 3-5 per year. Funding for next few hoists in hand. Order forthcoming. – *planning to award follow-on contract for 3-5 hoists in FY25. Remaining hoists dependent on availability of appropriated \$\$.*
  - Safety handrails – Contracted awarded. Construction FY24 ~ July or August. First two batches' welds have failed inspection. *Waiting for delivery of third batch*
  - SLABS – Phase 2 Approved. Fully Funded. Solicitation went out. Bid was 3x Government estimate. Likely to cancel solicitation. – *solicitation cancelled, working on plan for additional funding.*
- MCN Spillway Gate Replacements
  - Phase 1a approval pending 2024 Capital Work Group Meeting – *Approved March 2024, Phase 1a in progress.*
  - Phase 1 design in FY24-25 – *Phase 1 completion in FY26.*
  - Award: -- *dependent on availability of appropriated funding; may award in FY26.*
  - New spillway gates delivered FY26?: Three per year? – *FY27 or later.*
- MCN Spillway Gate Dogging Mechanism Repair underway with FY23 NREX funds.
  - Funded. Repairs to occur in FY25 and complete in FY26. Working
- MCN Spillway Gate Repair Pit Upgrade
  - Phase 1a has been approved, but no appropriated match – *still on hold pending appropriated match.*
  - Lower priority since gates are to be replaced. Project wants this to be higher priority. In current condition, cannot be used.
  - Repair pit will likely be used for storage when new spillway gates start to be delivered.
- Modeling – Latest estimate, \$2.3 M to create new model
  - Completed powerhouse and spillway. Constructing headbay, cutoff wall under the model, and parts of tailgate.
  - Estimated November 2024 for model completion.
  - December Model Calibration. January modelling trials.



## Physical Model Runs

1. Original spill table patterns for reference
2. Existing spill tables with split-leaf gates through range of flows  
Vary powerhouse operations, unit availability
3. Split-leaf gates with bays 1&2 open
4. Low flow/spill operations for navigation
5. Vary tailrace elevations, John Day MOP vs. MIP
- 6.



US Army Corps of Engineers

NO.	DATE	DESCRIPTION

DESIGNED BY S. MACHAM DRAWN BY J. M. ... CHECKED BY J. M. ... DATE JULY 2004 PROJECT WALLA WALLA DAM CONTRACT NO. FILE NO. SHEET NO. PROJECT NO.	U.S. ARMY CORPS OF ENGINEERS WALLA WALLA DISTRICT WALLA WALLA, WASHINGTON
---	---

MINORITY LOCK AND DAM COLLEGE WASHINGTON SPILLWAY LIFT AUXILIARY BEAM (L&D) SPILLWAY LIFT AUXILIARY BEAM ISOMETRIC
--

SHEET ID <b>G-004</b>
--------------------------

FINAL

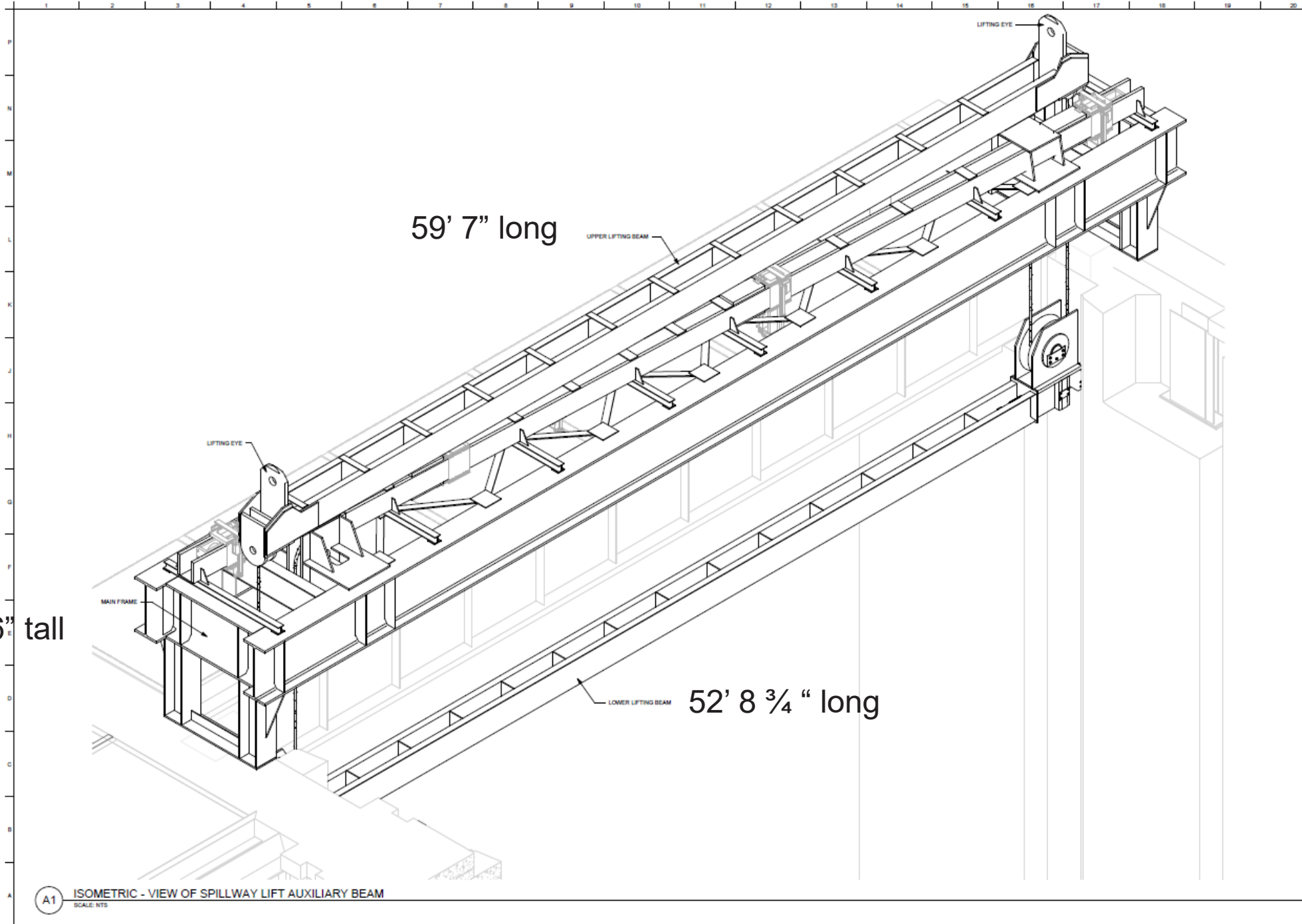

A1 ISOMETRIC - VIEW OF SPILLWAY LIFT AUXILIARY BEAM  
SCALE: NTS





®







# MODIFIED SPILL OPERATIONS

Retain two TSW's in normal location

Move 13 gates and hoists to upstream slot and use in split leaf configuration

- Construct new control cables
- Procure materials for handrails with Small Cap – Contract awarded.
  - Assemble handrails in-house
- 13 gates are in upstream slots
- 11 hoists moved to upstream slots. Cranes to be used for two gates

Retain 7 gates in downstream slot closed in full gate configuration

- Needed to maintain Standard Project Flood (SPF) capacity
- Incorporate use of SLAB's when available
- Modeling estimate 125% TDG spill level with split-leaf spill, ~220 kcfs (vs. 260-270 in 2023)

No change to spill operations at other projects

- 24MCN02 MFR
  - Gates 1 & 2 are in use
- Spill Tables and FPP change form developed.
- Cranes operating gates 6 & 9 cannot be adjusted hourly.
- Maintenance has reduced powerhouse capacity;
  - Increased summer spill and elevating TDG

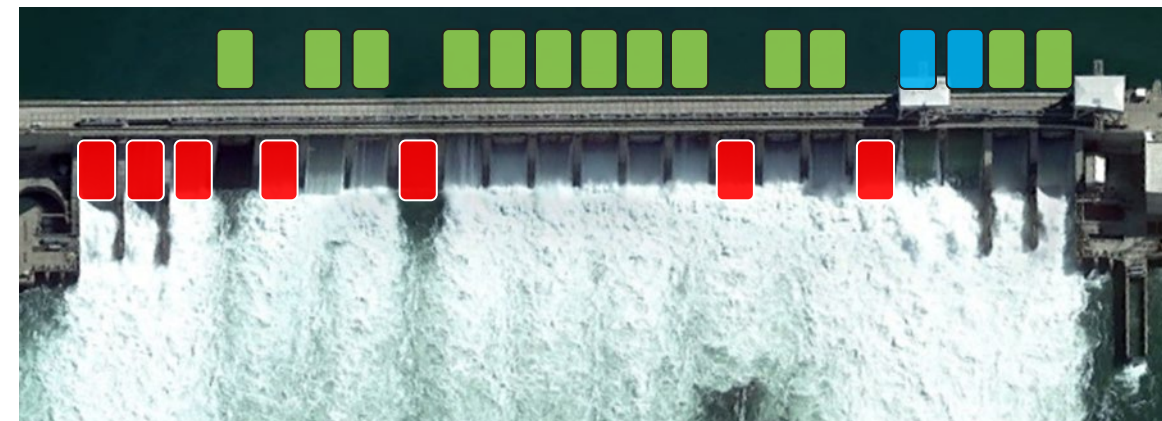
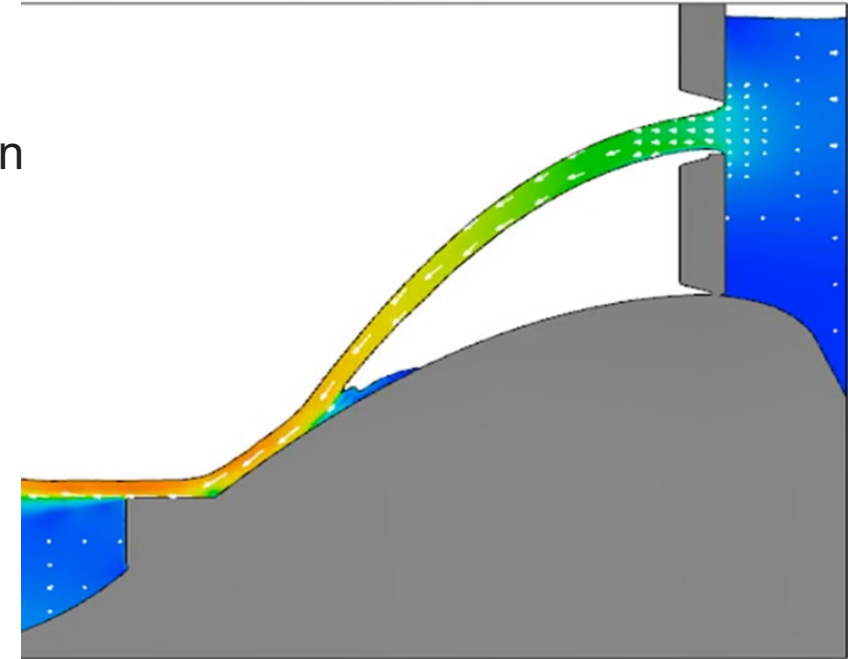



# MODIFIED SPILLWAY OPERATION EVALUATIONS

SRWG has met several times to discuss evaluation plans

## Research Summary

### **FY24 DIRECT INJURY STUDY OBJECTIVES:**

1. Estimate direct injury and survival of yearling Chinook salmon passing through a McNary Spillbay after being set in the upstream slot in split-leaf operation by direct releases of fish equipped with balloon tags at two different elevations. (Sample sizes sufficient to estimate with a precision of  $\pm 5\%$  @ 95% Confidence Interval [CI]).
2. Estimate direct injury and survival of yearling Chinook salmon passing through McNary Dam TSW by direct releases of fish equipped with balloon tags at two different elevations. (Sample sizes sufficient to estimate with a precision of  $\pm 5\%$  @ 95% CI).

### **FY24 ACTIVE TAG STUDY OBJECTIVES:**

1. Estimate spillway survival of out-migrating juvenile salmonids passing through McNary Dam with split-leaf spillway operations from dam face detections to outside of project influence downstream.
2. Estimate survival of out-migrating juvenile salmonids passing through all passage routes at McNary Dam with split-leaf spillway operations.
  - a. Estimate tailrace egress time for juvenile salmonids downstream of McNary Dam.
  - b. Estimate spillway passage efficiency (SPE) for split-leaf spillway operations at McNary Dam.
  - c. Estimate forebay survival and forebay residence time for split-leaf spillway operations at McNary Dam.

Evaluations are intended to be early spring. Before April spill season if possible.

Balloon Tag Study Completed. Draft report reviewed.

PNNL is analyzing data for report, available winter.



# SPILLWAY GATE HOIST REPLACEMENTS

## Old Hoist Design

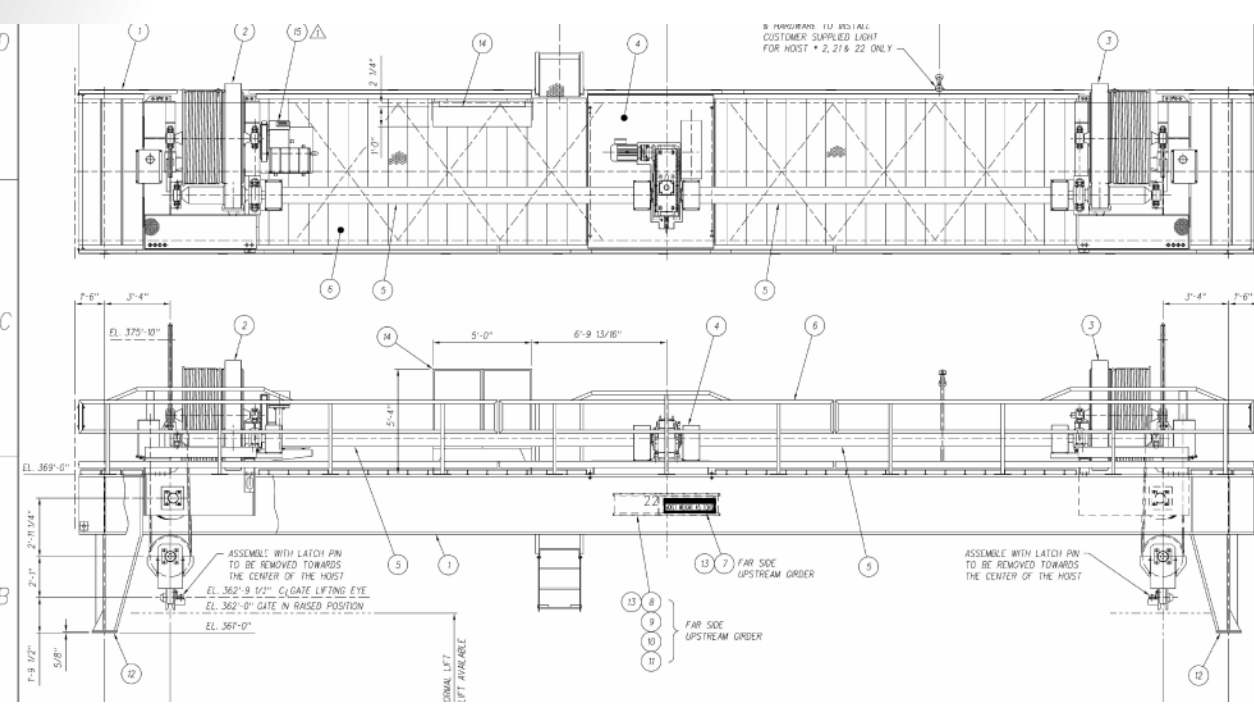

## New Hoist Design

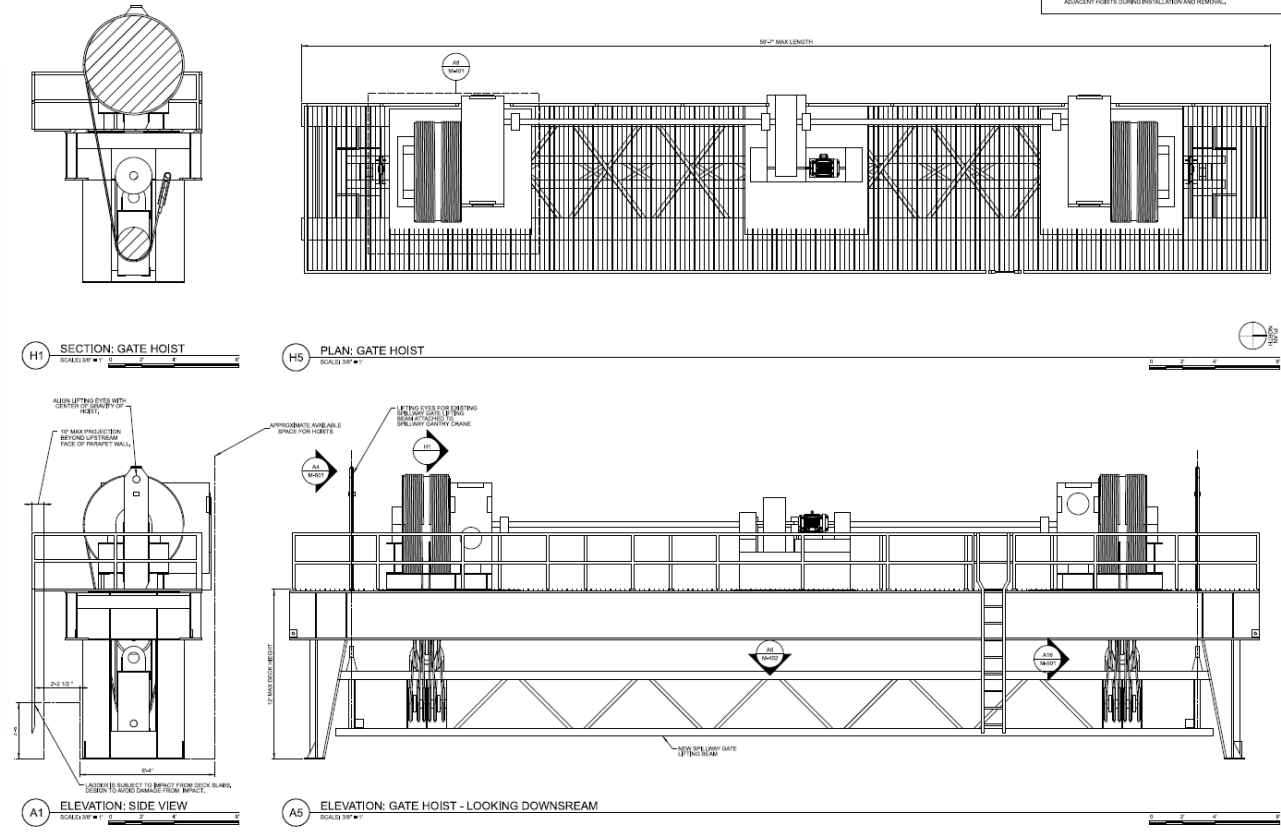

REMOVE METAL FROM HOIST BLANK, OTHER THAN HOIST HOIST FROM BLANK.  
 REMOVE METAL FROM HOIST BLANK, OTHER THAN HOIST HOIST FROM BLANK.



# SPILLWAY GATE HOIST REPLACEMENTS

## Old Hoist Design

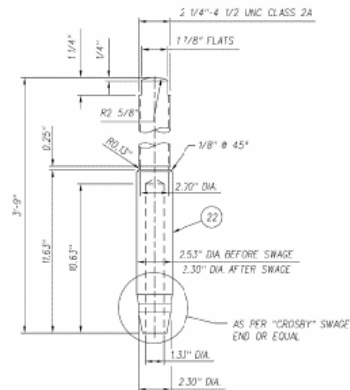
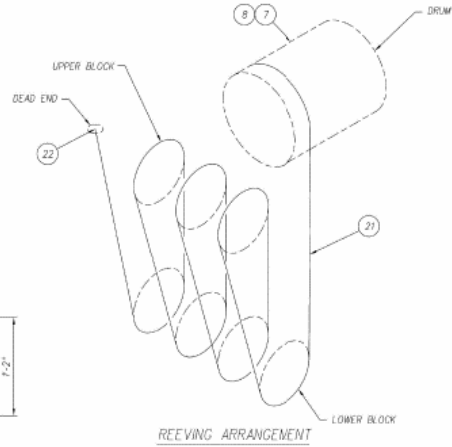
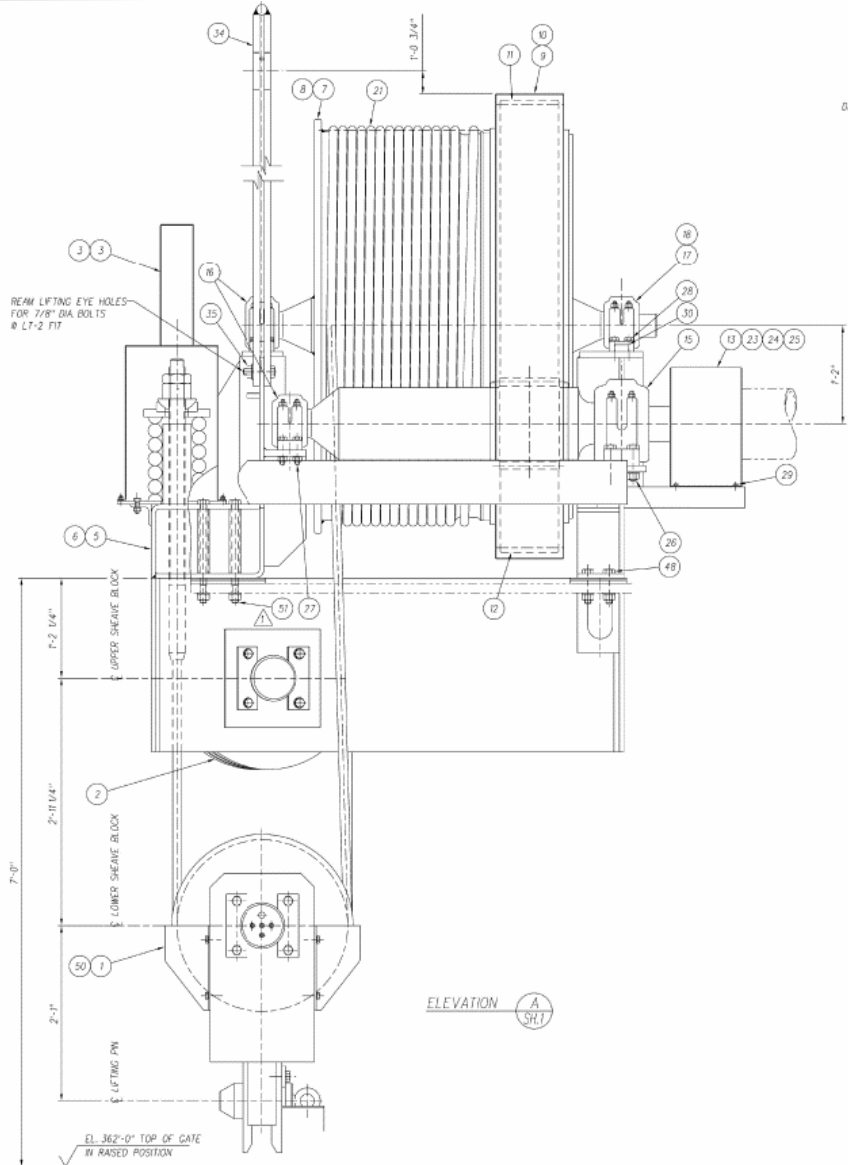

### DEAD END SWAGED WIRE ROPE FITTING

CUSTOM MADE BY "CROSBY" OR EQUAL FORGED FROM SPECIAL BAR QUALITY CARBON STEEL, SUITABLE FOR COLD FORMING. HARDNESS CONTROLLED BY SPHEROIDIZE ANNEALING EFFICIENCY RATING TO BE 100% BASED ON THE CATALOG STRENGTH OF THE WIRE ROPE PROOF LOAD IN ACCORDANCE WITH AISI830.9

UNLESS OTHERWISE SPECIFIED	
BRACKETS - 316 - OVER 24 FEET LONG	
BRACKETS - 316 - 24 FEET AND LESS	
BRACKETS - 316 - WITH FINE MILL	
316-03	ANGLES
316-015	316-015
316-020	316-020
MACHINED SURFACE FINISHED	
TREATMENT	
BREAK ALL SHARP EDGES	

## New Hoist Design

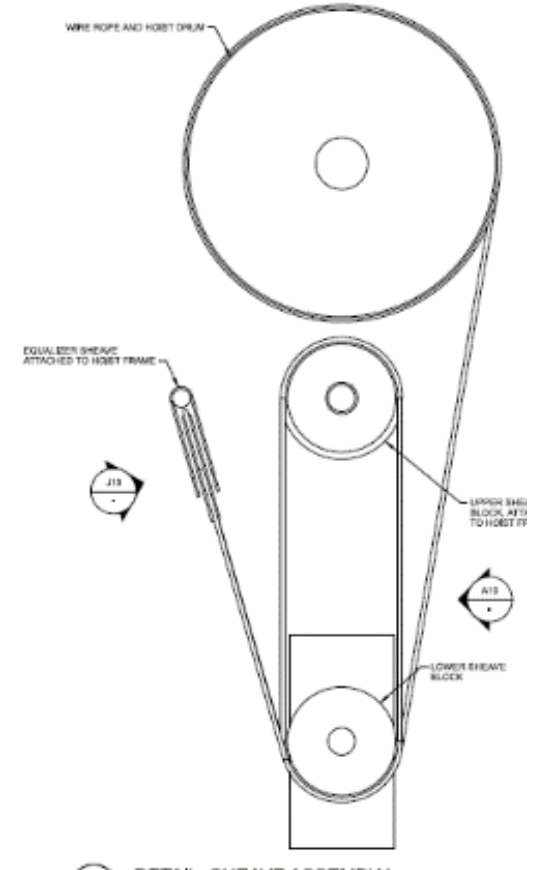
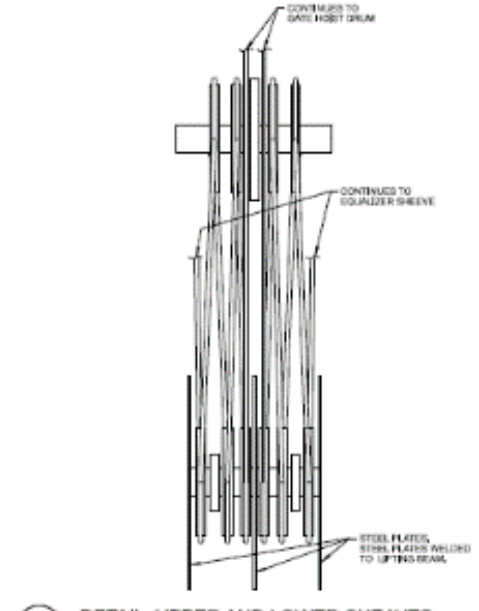
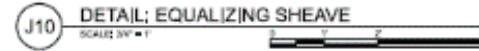
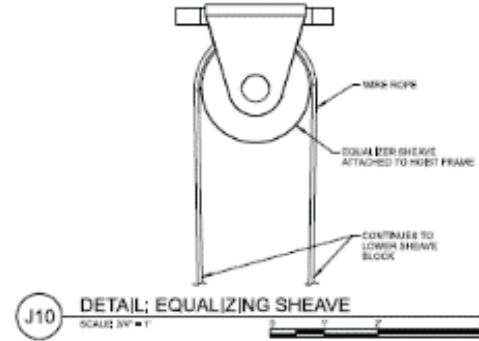





# MODIFIED SPILL OPERATIONS

Changes in the spill gate and hoist configuration and spill operations creates uncertainty for fish passage at McNary.

## Potential Fish Impacts Include:

- Altered forebay attraction (SPE and FGE) and tailrace egress conditions, which may cause;
  - Longer juvenile travel times in the forebay and tailrace
  - Reduced juvenile reach survival
- Passage through split-leaf gate openings may cause physical injury
- Estimated lower gas cap spill levels would produce increased PITPH
- Poor tailrace flow conditions (eddy formation) may cause adult fish passage delays





TDG Results Table						
Date	Time UTC	Air Pressure	TDG	Depth	TDG	Location Notes
MM/dd/yyyy	hh:mm:ss	mmHg	mmHg	ft	%	
6/10/2024	18:49:00	755	925	6.3	122.6%	Point 1 (same location as MCPW but at shallower depth)
6/10/2024	19:06:00	755	926	6.4	122.7%	Point 2
6/10/2024	19:25:00	754	930	6.3	123.2%	Point 3
6/10/2024	19:43:00	754	933	6.6	123.7%	Point 4
6/10/2024	20:19:00	754	927	5.9	123.0%	Point 5
6/10/2024	20:43:00	754	921	5.6	122.1%	Point 6
6/10/2024	21:04:00	754	910	6.3	120.8%	Point 7
6/10/2024	21:53:00	753	909	6.0	118.8%	Point 8
						<b>Flow 219 k</b>
						<b>Spill 159 k</b>

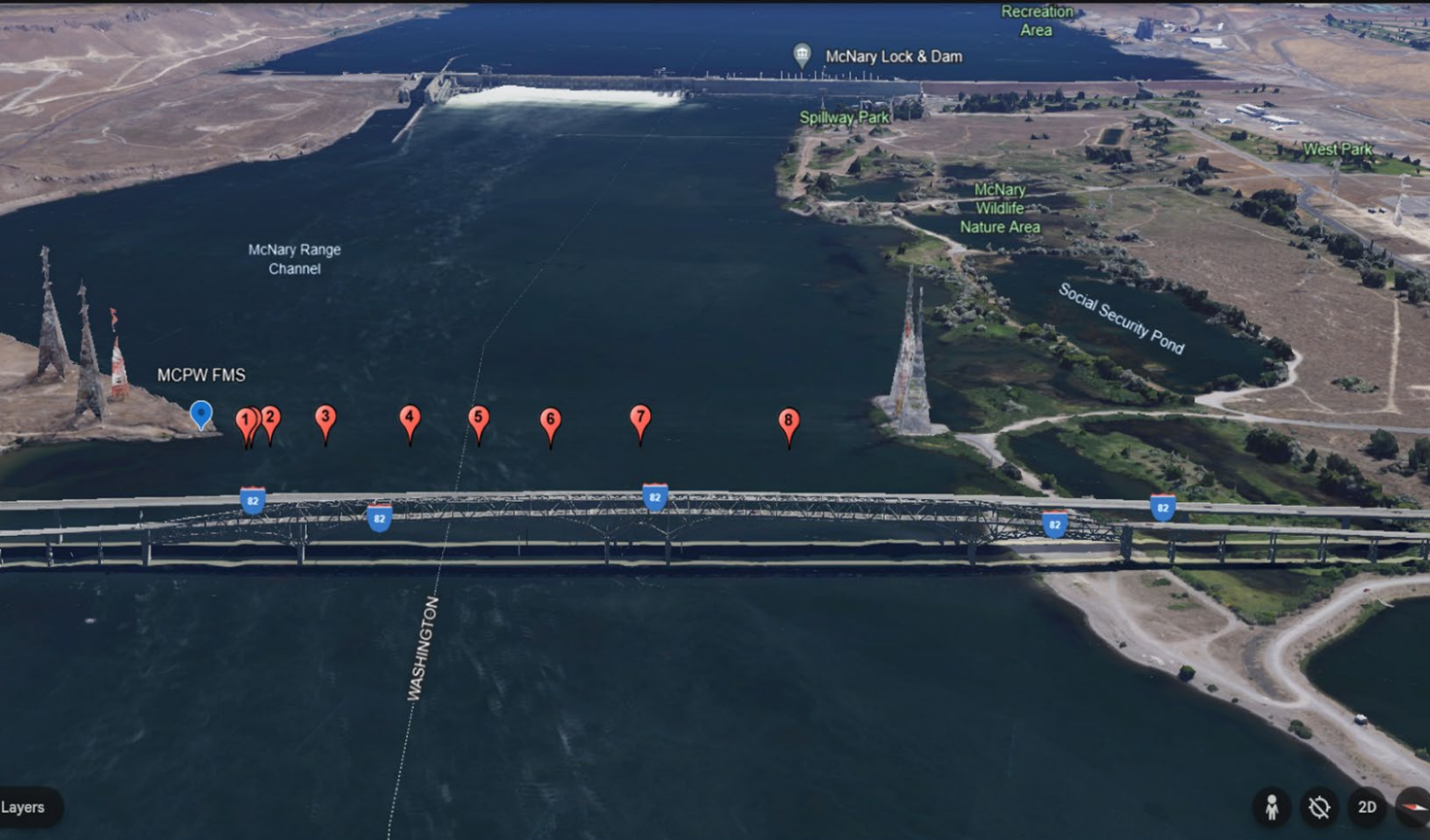

Percent TDG at 2m Depth vs. Data Collection Point

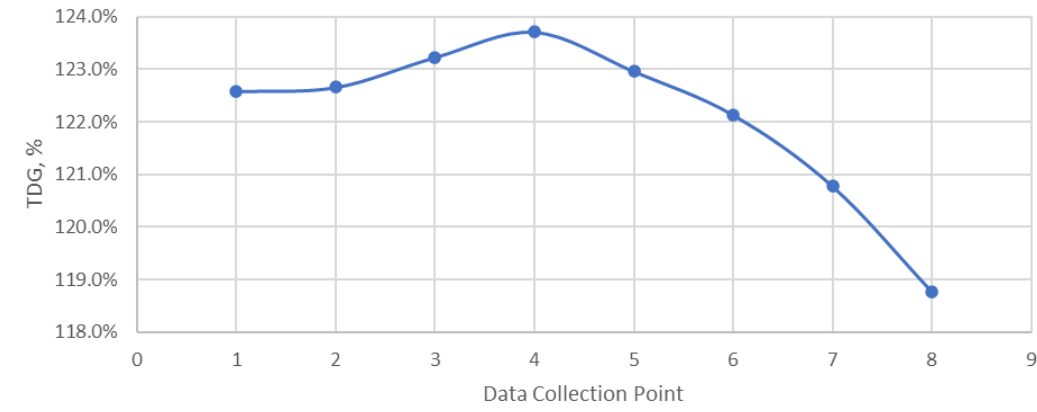

TDG was measured and observed for each of the red numbered pinpoints spanning the Columbia River below McNary Dam and upstream of the I-82 bridge. Points 1 through 8 represent the TDG measurements taken at approximately 6-ft (2m) depths.

Instruments passed QA/QC post calibration tests on 13 June 2024.

Field Personnel: Russ Heaton, Omar Lopez



**TDG Results Table**

Date	Time UTC	Air Pressure	TDG	Depth	TDG	Location Notes
MM/dd/yyyy	hh:mm:ss	mmHg	mmHg	ft	%	
5/30/2024	17:08:00	762.6	919	18.2	120.5%	Correlation to MCPW. FMS readings: TDG = 120.7%, Depth = 19.0 ft
5/30/2024	17:46:00	762.4	919	6.8	120.5%	Point 1
5/30/2024	18:10:00	762.2	922	6.0	120.9%	Point 2
5/30/2024	18:36:00	761.9	923	5.7	121.1%	Point 3
5/30/2024	19:50:00	761.2	925	6.1	121.5%	Point 4
5/30/2024	20:16:00	761	920	5.8	120.9%	Point 5
5/30/2024	20:36:00	760.8	917	6.0	120.5%	Point 6
5/30/2024	21:18:00	760.4	905	5.4	119.0%	Point 7
5/30/2024	21:50:00	760	889	6.0	116.9%	Point 8

**Flow 204 kcfs**  
**Spill 144 kcfs**

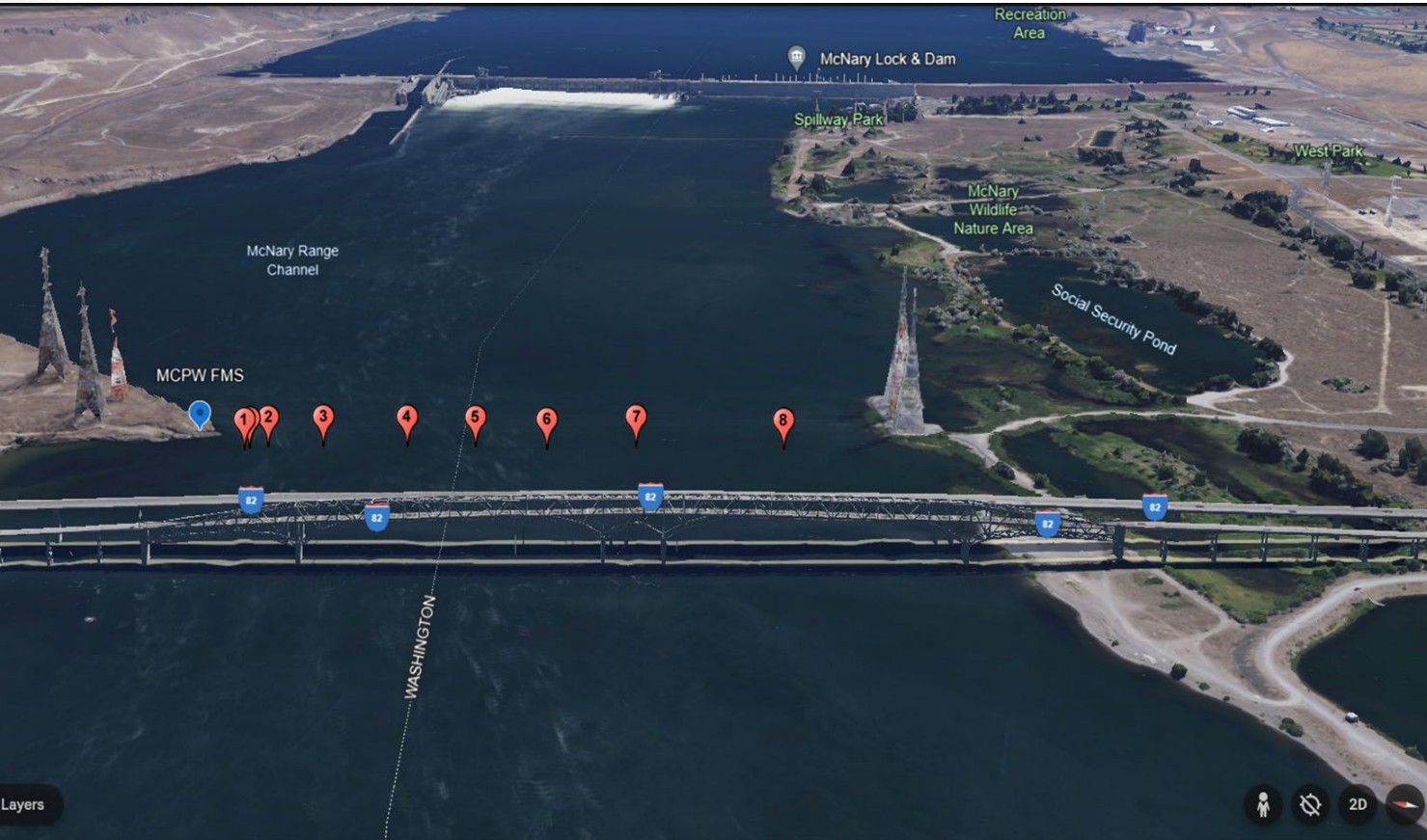

Percent TDG at 2m Depth vs. Data Collection Point

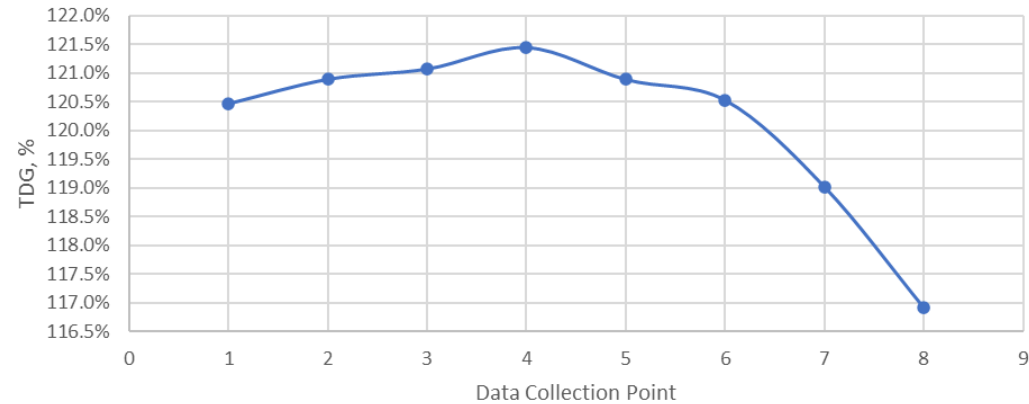

TDG was measured and observed for each of the red pinpoints spanning the Columbia River below McNary Dam and upstream of the I-82 bridge. Points 1 through 8 represent the TDG measurements taken at approximately 6-ft (2m) depths. The red star pin represents the correlation measurement with the Fixed Monitoring Station (FMS) MCPW, taken at approximately 19-ft depth.

Instruments passed QA/QC post calibration tests on 5 June 2024.

Field Personnel: David Towsley, Mishael Umlor



TDG Results Table						
Date	Time UTC	Air Pressure	TDG	Depth	TDG	Field Notes
MM/dd/yyyy	hh:mm:ss	mmHg	mmHg	ft	%	
4/16/2024	18:00:00	761.0	894	21.3	117.5	MCPW FMS reading: TDG = 117.4%, Depth = 19.0 ft
4/16/2024	18:08:00	761.0	893	5.6	117.3	Point 1
4/16/2024	18:22:00	761.0	899	6.1	118.1	Point 2
4/16/2024	18:38:00	760.9	902	7.6	118.5	Point 3
4/16/2024	19:50:00	760.3	902	6.1	118.6	Point 4
4/16/2024	20:20:00	760.0	900	6.1	118.4	Point 5
4/16/2024	20:48:00	759.9	896	6.6	117.8	Point 6
4/16/2024	21:25:00	760.6	885	6.8	116.4	Point 7
4/16/2024	21:52:00	759.3	880	6.5	115.8	Point 8
						<b>Flow 174 kcfs</b>
						<b>Spill 115 kcfs</b>

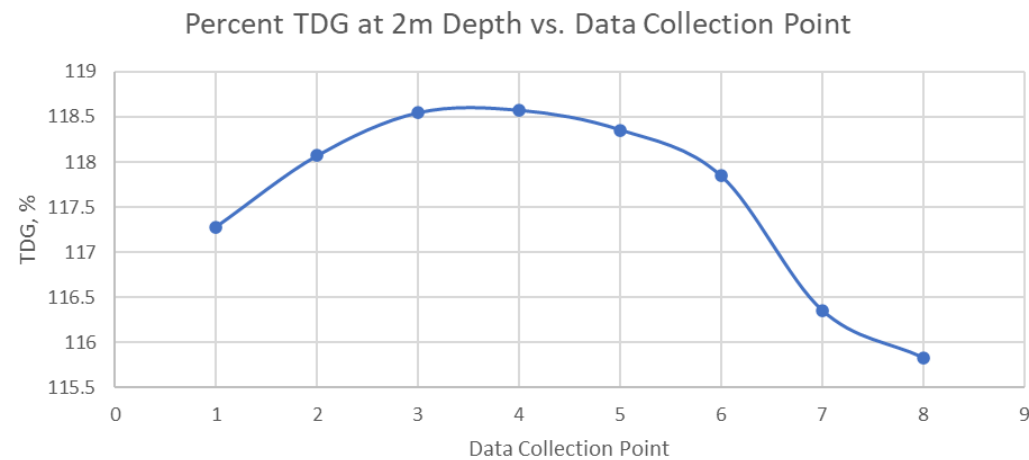
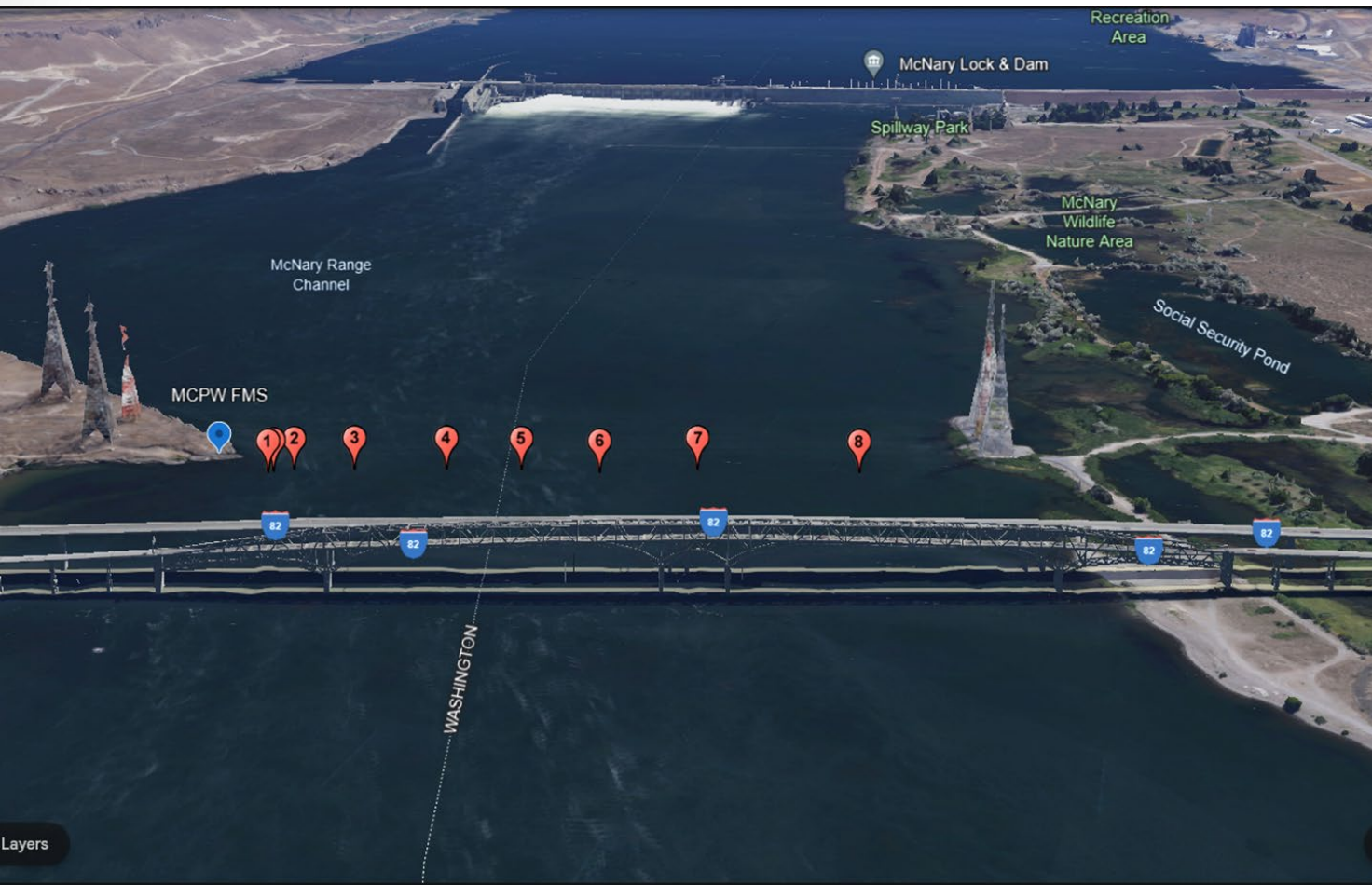

TDG was measured and observed for each of the red pinpoints spanning the Columbia River below McNary Dam and upstream of the I-82 bridge. Points 1 through 8 represent the TDG measurements taken at approximately 6-ft depths. The red star pin represents the correlation measurement with the Fixed Monitoring Station (FMS) MCPW, taken at approximately 20-ft depth.

Instruments passed QA/QC post calibration tests on 17 APR 2024.

Field Personnel: Mishael Umlor, David Towsley



1. If lower flows are expected, spill gates 1 and 2 will remain in the downstream slot and opened to 4 stops (~7 kcfs spill) each and left in that position for the duration of the spill season based on the following hydrologic criteria:
  - a. The Dalles April-August ESP-10 water supply forecast volume from the NWRFC is less than 90 MAF **on 5 April**, and
  - b. The STP forecast shows McNary inflows remaining below 350 kcfs through the spring freshet, and
  - c. Internal Corps system Flood Risk Management (FRM) analyses conducted weekly indicate a high probability of McNary inflows remaining below 350 kcfs through the spring freshet.

# McNary Inflow

Corps of Engineers Projections Based on 43 Ensemble Streamflow Prediction Traces  
by the Northwest River Forecast Center, National Weather Service, NOAA

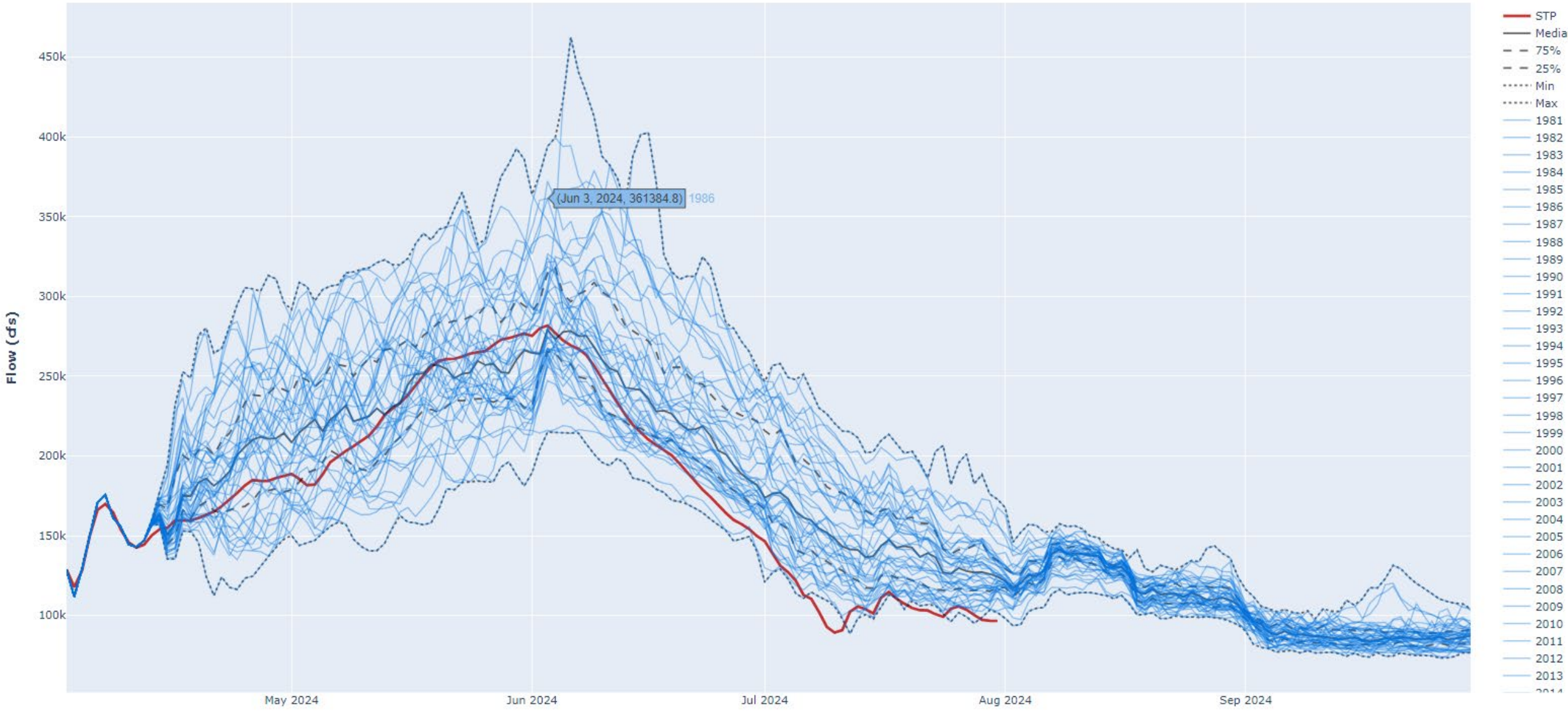



## McNary Existing and Draft New Efficiency Curves

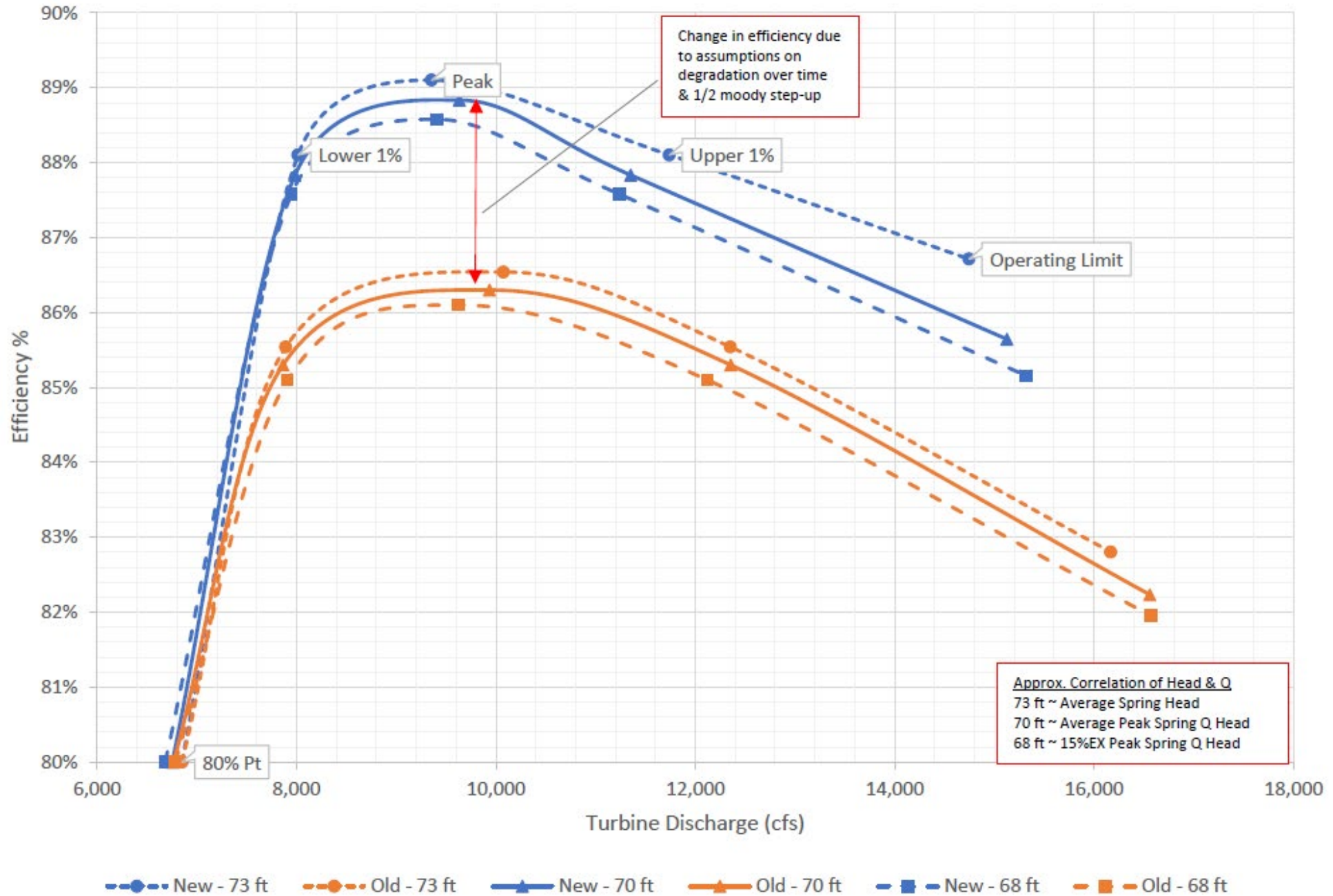









®



06/11/2023 10:55

